

Silicon Carbide for Automotive

SemiQ's SiC products provide the best-in-class reliability, quality, and performance for Automotive applications. We offer 1200V MOSFETs in both module and discrete packages, designed to maximize efficiency gains.

DC-DC converters are essential for maintaining the electrical systems of an electric vehicle. They ensure that all subsystems receive the proper voltage levels needed for their operation while maximizing energy efficiency and safety.

This contributes to the seamless integration of high-voltage components with the low-voltage systems in modern electric vehicles.

Benefits of SemiQ QSiC™ in Automotive



High Efficiency



Enhanced Reliability



Wide Range of Voltages and Currents



Reduced Power Dissipation



Temperature Tolerance



Contribution to Sustainability

Typical DC-DC Converter Schematic

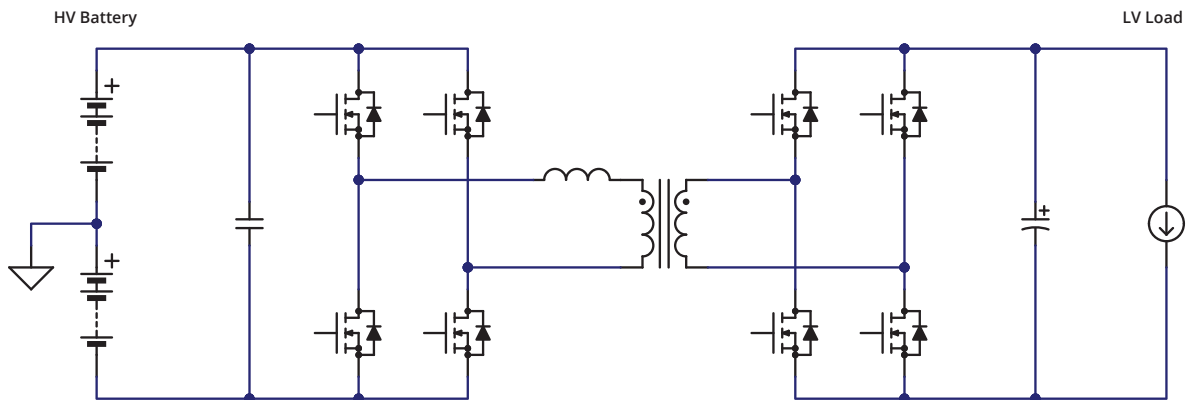



Silicon Carbide for Automotive

Silicon Carbide (SiC) semiconductors are driving a profound transformation in the automotive industry, offering a host of benefits across key applications like DC-DC converters, on-board chargers, and e-compressors. SiC's remarkable power handling capabilities and reduced switching losses are revolutionizing energy management in electric vehicles (EVs). In DC-DC converters, SiC devices enable higher efficiency, compact designs, and increased power density, optimizing energy transfer between various voltage levels in the vehicle's electrical system. On-board chargers benefit from SiC's faster switching speeds and lower losses, facilitating quicker charging times and extending the driving range of EVs. Moreover, SiC e-compressors enhance the efficiency of electric air conditioning systems, contributing to overall energy savings and improved thermal management. By integrating SiC semiconductors, automakers can elevate the performance, range, and sustainability of electric vehicles, driving forward the transition to clean transportation.

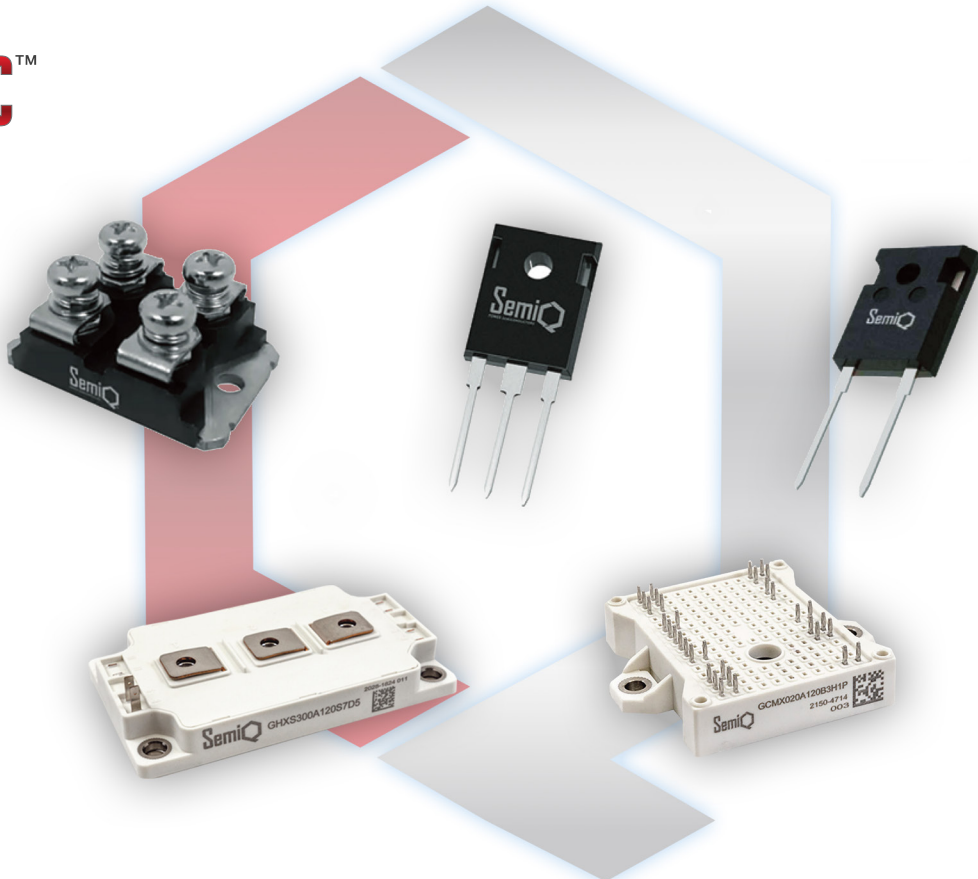

SemiQ specializes in providing high-quality, efficient standard, and custom Silicon Carbide (SiC) Power Semiconductors for high-voltage applications. Our product portfolio includes MOSFETs and diodes, available in discrete, module and bare die that combine high-performance with industry-leading reliability.

