

Silicon Carbide for EV Fast Charging

SemiQ offers a broad spectrum of Silicon Carbide (SiC) diodes, modules and MOSFETs. These components meet the demands of high efficiency EV Fast Charging designs with best-in-class reliability, quality, and performance.

Our 1200V diodes in modules and discrete packages in a range of voltages and currents give the ultimate in efficiency gains for DC Fast Charging systems to 300kW and beyond.

Benefits of SemiQ QSiC™ in EV Fast Charging



High Efficiency



Reduced Operational Temperatures



Long-term Reliability



Reduced Design Complexity versus Silicon



Over 54M Hours of HTRB/H3TRB Testing



Unidirectional and Bi-directional Conversion

Typical EV Charging Schematic

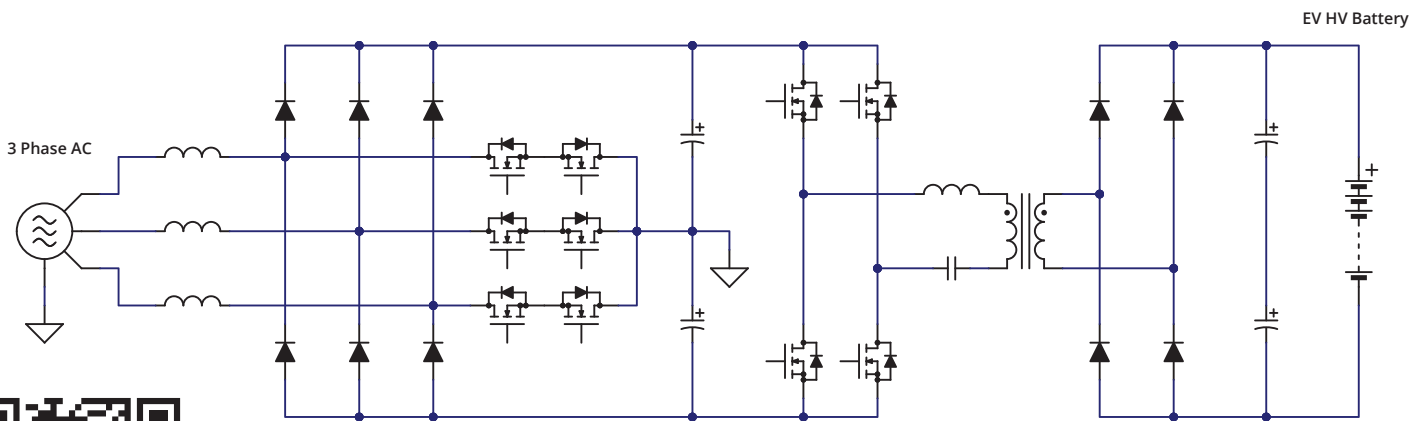

Silicon Carbide for EV Fast Charging

SemiQ 1200V QSiC™ MOSFETs have been optimized for market trend toward 800V DC Bus voltage for high power On-Board Charger (OBC) such as 11kW or 22kW charger systems.

The best results can be obtained from an optimized three-phase design at 800V Bus. The Vienna rectifier is a popular choice for three-phase power correction due to its high efficiency, Continuous Conduction Mode (CCM) operation, three-level switching, and reduced voltage stress on the power devices.

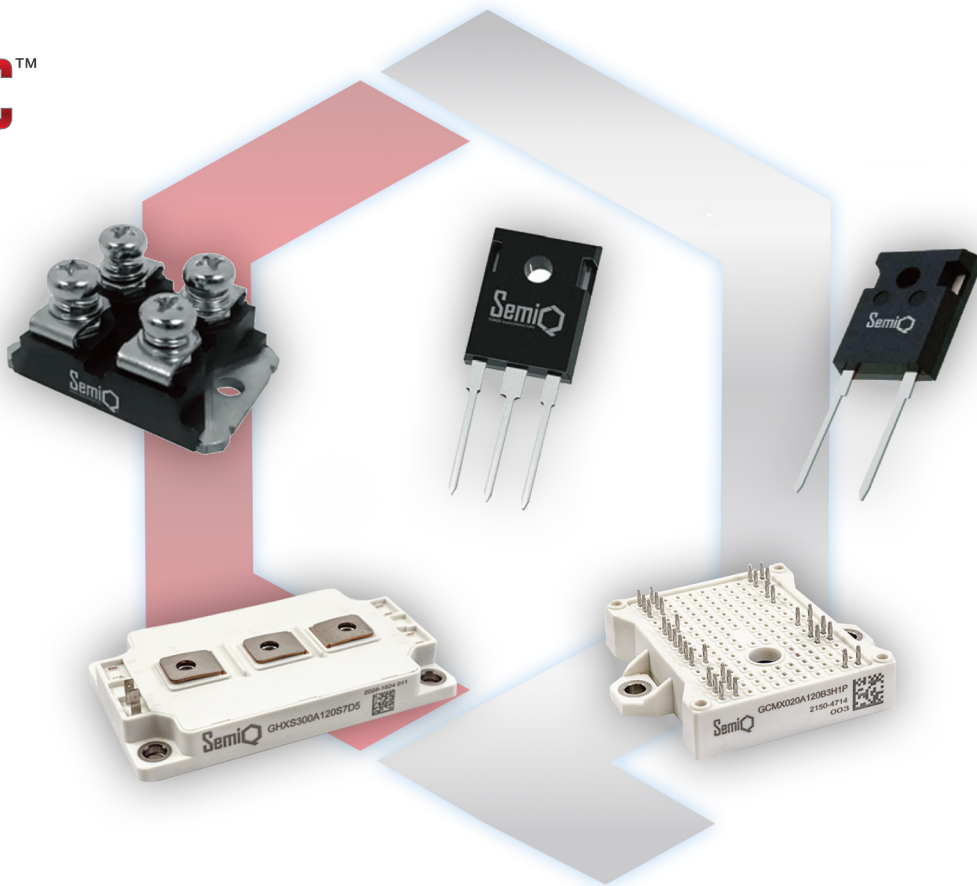

SemiQ specializes in providing high-quality, efficient standard, and custom Silicon Carbide (SiC) Power Semiconductors for high-voltage applications. Our product portfolio includes MOSFETs and diodes, available in discrete, module and bare die that combine high-performance with industry-leading reliability.